

1. Name the parts of the trombone on the picture below.

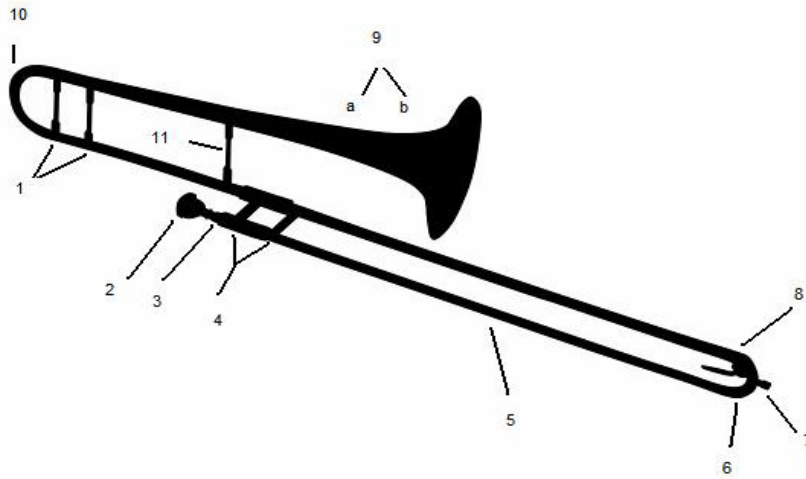

1.

6.

2.

7.

3.

8.

4.

9a.

9b.

5.

10.

11.

2. What is a good mouthpiece to start MOST beginners?
  
3. What mouthpiece works well if they have trouble with the mouthpiece in question #2?
  
4. What is a standard bass trombone mouthpiece?
  
5. If that mouthpiece is too large, what is another alternative?
  
6. What are the two steps that will ensure good posture for playing?
  
7. True/False – The trombonist should bring the body to the trombone.
  
8. List the four steps to forming an embouchure.
  1. \_\_\_\_\_
  2. \_\_\_\_\_
  3. \_\_\_\_\_
  4. \_\_\_\_\_
  
9. What is a good general vertical setting for the mouthpiece on the embouchure?
  
10. True/False – Arnold Jacobs told his students to expand to breathe, so that they can get the largest breath possible.
  
11. When should a student switch to a large bore trombone?

12. What are the two types of trombone mutes? Give a brief description of each.

13. A parent calls you and tells you that they found Little Johnny a Yamaha Intermediate trombone for \$1000 new, when all of those Bach Stradivarius and Getzen Customs are over \$2000. Do you tell them that the Yamaha Intermediate is a good buy? Why or why not?

14. Match these 14 professional trombonists in the first column with their “gig”.

- |                       |  |
|-----------------------|--|
| A. Joseph Alessi      | ___ BSO Principal Trombonist           |
| B. Mark Lawrence      | ___ New York Philharmonic Principal    |
| C. Douglas Yeo        | ___ San Francisco Symphony (retired)   |
| D. Emory Remington    | ___ World Renowned Soloist             |
| E. Arthur Pryor       | ___ BSO Bass Trombonist (retired )     |
| F. Charles Vernon     | ___ “Bebop” Era Jazz Trombonist        |
| G. Christian Lindberg | ___ BSO Bass Trombonist                |
| H. James Markey       | ___ Chicago Symphony Bass Trombonist   |
| I. Toby Oft           | ___ Sousa Band Era Soloist             |
| J. J. Johnson         | ___ Eastman School of Music            |
| K. Nate Zgonc         | ___ Atlanta Symphony trombone          |
| L. Barry Hearne       | ___ San Antonio principal trombone     |
| M. John Romero        | ___ Dallas Symphony principal trombone |
| N. Steve Peterson     | ___ Fort Worth Symphony principal      |

15. Pick one of the above and write a paragraph about him below. Why is he important? What are his contributions to the trombone world?

16. Write out the harmonic series on Bb in first position. The first note is given.

